

WP55-12 12Volt 55Ah

Specifications

Nominal Voltage(V) **12V**

Nominal Capacity

20 hour rate	(2.75A to 10.50V)	55Ah
10 hour rate	(5.225A to 10.50V)	52.25Ah
5 hour rate	(9.35A to 10.20V)	46.75Ah
1 C	(55A to 9.60V)	31.17Ah
3 C	(165A to 9.60V)	22Ah

Weight **Approx. 17.0kg(37.4Lbs.)**

Internal Resistance (at 1KHz) **Approx. 8 mΩ**

Maximum Discharge Current for

5 seconds: **660A**

Charging Methods at 25 (77)

Cycle use:

Charging Voltage **14.4 to 15.0V**

Coefficient -5.0mV/ /cell

Maximum Charging Current : **16.5A**

Standby use:

Float Charging Voltage **13.5 to 13.8V**

Coefficient -3.0mV/ /cell

Operating Temperature Range

Charge **-15 (5) to 40 (104)**

Discharge **-15 (5) to 50 (122)**

Storage **-15 (5) to 40 (104)**

Charge Retention (shelf life) at 20 (68)

1 month **98%**

3 month **94%**

6 month **85%**

Case Material **ABS UL94 HB**

Option: Flammability resistance of (UL94 V-0)

Terminal **F15**



Dimensions

mm(inch)

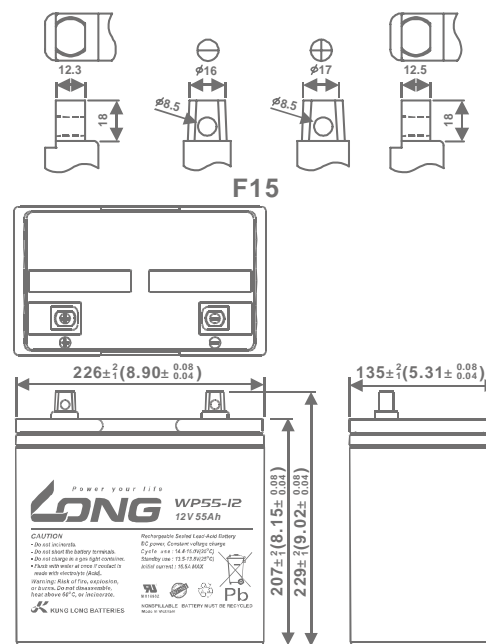

(v) FOR 12V BATTERY Discharge Time VS. Discharge Current (25)

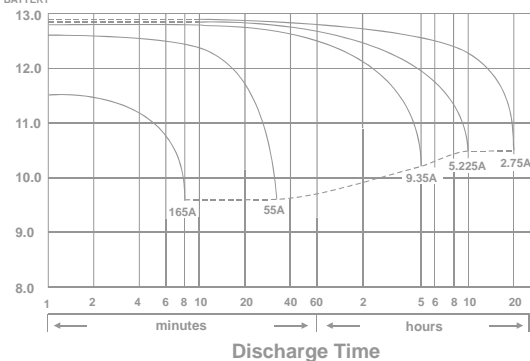

Effect of Temperature on Capacity 25 (77)

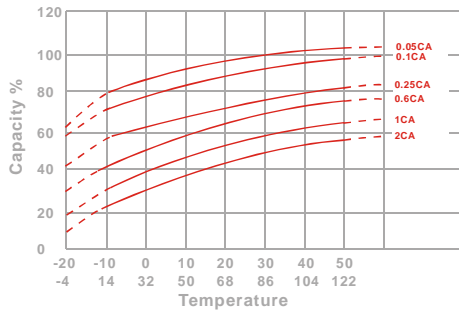

Capacity Retention Characteristic

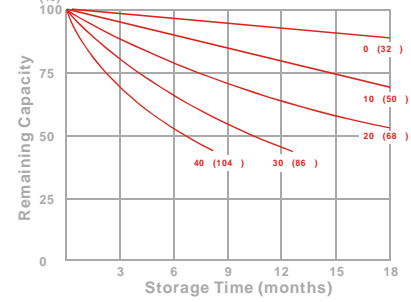

Trickle (or float) Service Life

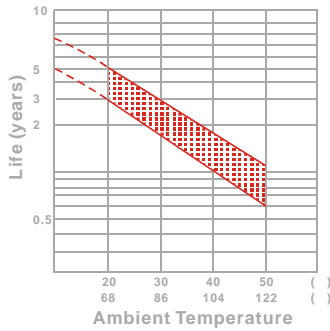

Cycle Service Life

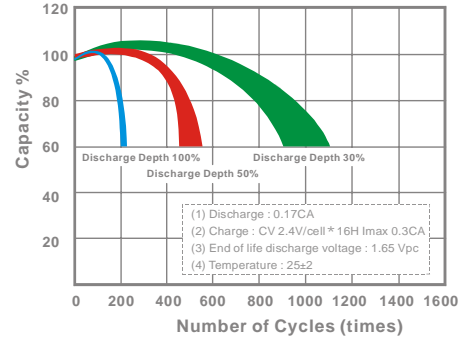

- PERFORMANCE DATA

Discharge Rates in Watts to Various End Voltages at 25 (77)

End Voltage		1.85V	1.80V	1.75V	1.70V	1.67V	1.65V	1.60V
5	min	328	381	413	430	434	438	444
10	min	210	244	265	276	278	281	285
15	min	163	187	202	209	211	213	215
30	min	86.9	99.5	107	111	112	113	115
60	min	64.7	67.5	69.3	70.8	71.3	72.0	72.6
120	min	32.5	34.7	36.2	37.2	37.5	37.8	38.3
180	min	26.3	28.2	29.2	29.8	30.0	30.3	30.6
240	min	21.8	23.0	23.7	24.2	24.3	24.5	24.6
300	min	18.3	19.3	20.0	20.3	20.5	20.7	20.9
600	min	10.6	11.1	11.4	11.6	11.6	11.7	11.7
1200	min	5.48	5.78	5.93	6.05	6.08	6.14	6.18

- Discharge Rates in Amperes to Various End Voltages at 25 (77)

End Voltage		1.85V	1.80V	1.75V	1.70V	1.67V	1.65V	1.60V
5	min	176	204	219	228	231	234	238
10	min	110	127	138	143	145	147	149
15	min	83.5	95.6	103	107	108	109	110
30	min	43.8	50.2	54.1	55.8	56.4	57.0	57.7
60	min	29.4	33.2	34.5	35.4	35.7	36.1	36.5
120	min	16.9	18.4	19.2	19.8	20.0	20.3	20.6
180	min	13.0	13.8	14.3	14.7	14.8	15.0	15.2
240	min	10.9	11.5	11.7	11.9	12.0	12.1	12.2
300	min	9.32	9.74	9.92	10.1	10.2	10.3	10.4
600	min	5.39	5.63	5.65	5.71	5.73	5.76	5.80
1200	min	2.76	2.89	2.96	3.00	3.01	3.03	3.05

All data on the spec. sheet is an average value:

The tolerance range : X<6min(+15%~-15%), 6min X<10min(+12%~-12%),10min X < 60min(+8%~-8%), X 60min(+5%~-5%)

021216-11



Head Quarter Service - TEL: +886-49-2254-777 FAX: +886-49-2255-139 E-mail: sales@mail.klb.com.tw
 USA Customer Service - TEL: +1-949-328-7936 FAX: +1-949-266-9917 E-mail: sales@kunglong.com
 Vietnam Customer Service - TEL: +84-72-3779666 FAX: +84-72-3779476 E-mail: sales@mail.klb.com.tw